



SEMI F47 Compliance Certificate
PULS Power Supply
EPRI Solutions Inc. PQ Star Test Program
Certification Date: 03/04/05

PQ Star Reference Number:
SEMIF47.099

Manufacturer: PULS

Product: Dimension 24Vdc Power Supply

Model Number: QT20.241

Serial Number (Unit Tested): 2522005

*See Attachment C for SEMI F47 Description
and Detailed Test Results.*

Test Configuration: The *Power Supplies*
were tested using SEMI F42 compliant voltage
sag generator equipment. See Attachment B
for details.

Test Date: 03/02/05

Test Location:
EPRI Solutions Inc.
942 Corridor Park Blvd
Knoxville, TN 37932

Electrical Environment:
480Vac Three Phase 60 Hz
380Vac Three Phase 50 Hz
(See Attachment A for details.)

This letter and subsequent documentation certifies that the Puls Dimension QT20.241 power supply detailed in this document, in its original configuration has been voltage sag tested per **SEMI F42** test protocol and was found to comply with the **SEMI F47** voltage sag immunity standard at 100% load, at 480Vac 60Hz, and 380Vac 50Hz. The unit should therefore be compliant throughout the rated operating range. This certification remains valid to the models tested only and as long as no component substitutions are made.

Certified by,

Scott Bunton
PQ Star Certification Specialist



PULS QT20.241 Power Supply



Attachment A – SEMI F47 Test Results

Testing was performed at EPRI Solutions’ Power Quality Laboratory in Knoxville, TN. The test protocol followed was SEMI F42 Test Method for Semiconductor Processing Equipment Voltage Sag Immunity. To ensure maximum accuracy of the test, a variable voltage source was used to set the voltage to exactly 480Vac 60Hz or 380Vac 50Hz. This was verified at the power supply with a qualified meter. During the voltage sag test, the power supply was connected to a programmable DC load bank and loaded to 100% of its rated output as shown in Table A-1.

Table A-2 lists all points tested per SEMI F42 test method. Figures A-1 and A-2 show the SEMI F47 ride-through curves at 480Vac and 380Vac, respectively. The specific SEMI test points are highlighted for both 50 and 60 Hz. The power supply was tested at points below the curve to fully characterize the unit. The output of the power supply did not deviate at any of the test points.

Table A-1 Power Supplies Ratings

Evaluated at 380Vac and 480Vac							
Manufacture	Power Supply	Vdc	I	R	W	Actual load	Result
PULS	QT20.241	24	20	1.2	480	100%	Passed

Table A-2. PULS QT20.241 Test Results

Duration			Percent of Nominal (Vab)			
Seconds	60Hz Cycles	50Hz Cycles	480Vac 60Hz	380Vac 50Hz	SEMI F47	Results
1	60	50	21%	45%	80%	Passed
0.5	30	25	21%	45%	80%	Passed
0.5	30	25	21%	45%	70%	Passed
0.25	15	12.5	21%	45%	70%	Passed
0.2	12	10	21%	45%	70%	Passed
0.2	12	10	21%	45%	50%	Passed
0.17	10	8.5	21%	45%	50%	Passed
0.08	5	4	21%	44%	50%	Passed
0.07	4	3.5	21%	44%	50%	Passed
0.05	3	2.5	21%	43%	50%	Passed
0.03	2	1.5	18%	40%	50%	Passed
0.02	1	1	0%	21%	50%	Passed

Figure A-1. PULS QT20.241 SEMI F47 Ride-Through Curve at 480Vac 60Hz

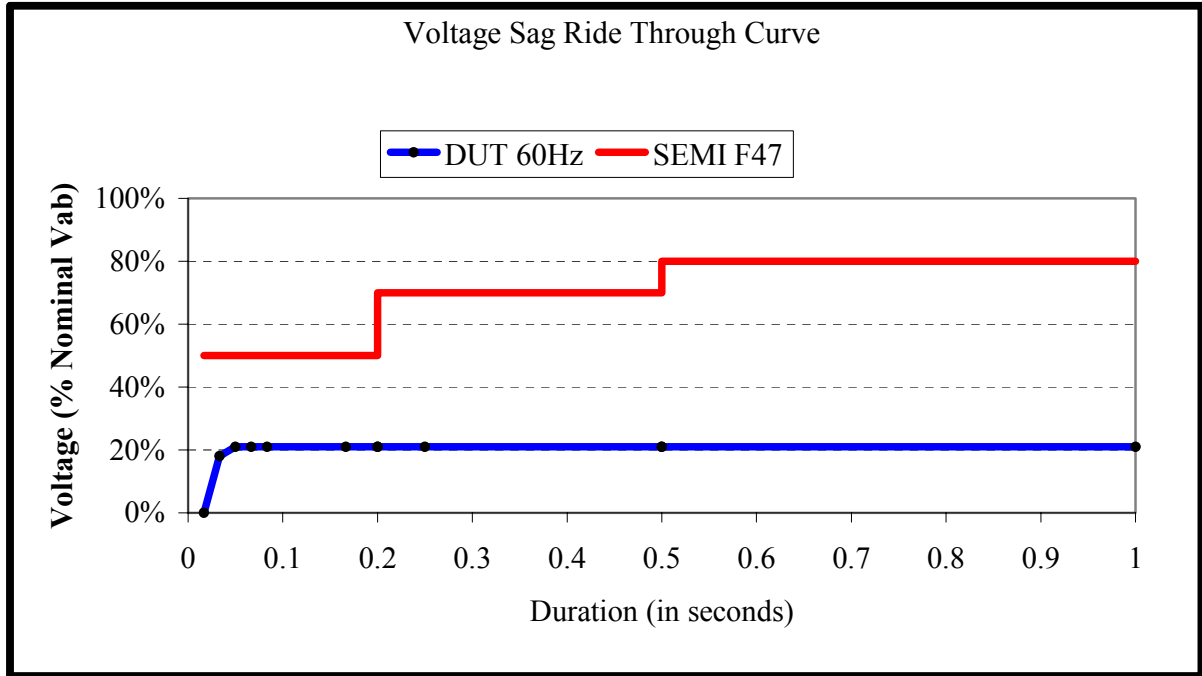
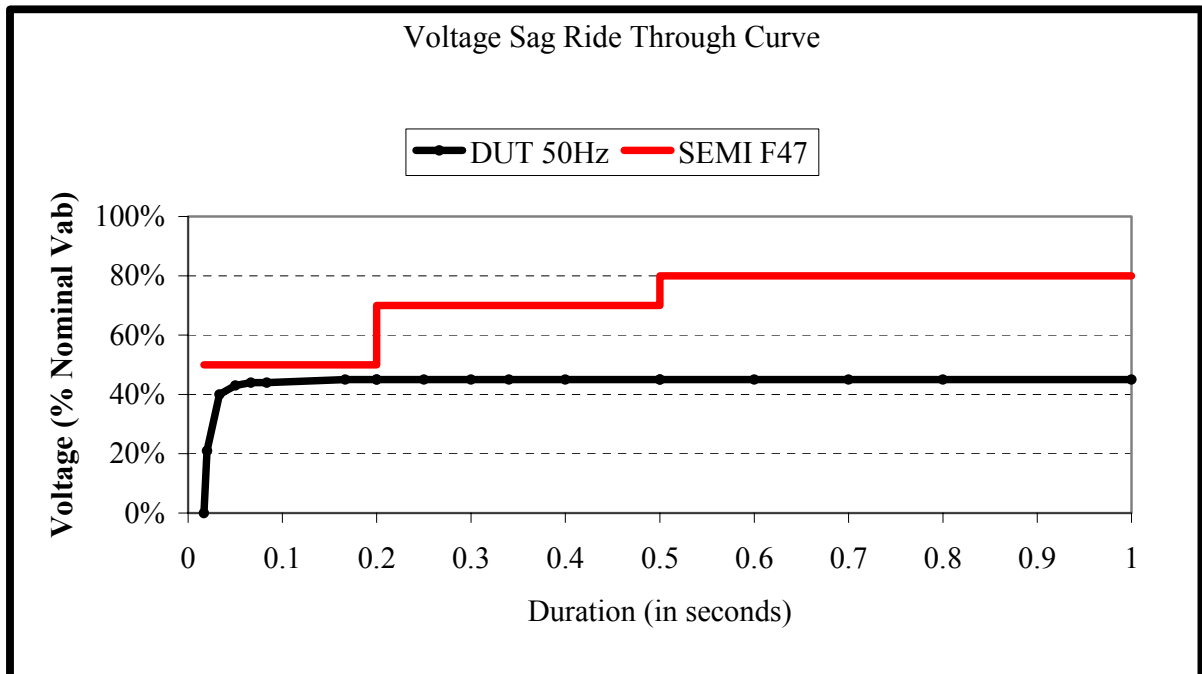

Figure A-2. PULS QT20.241 SEMI F47 Ride-Through Curve at 380Vac 50Hz





Electrical Environment

Steady state measurements were taken prior to testing. Table A-3 lists measurements taken to characterize the electrical environment of the power supply during SEMI F47 compliance testing, at 50/60 Hz.

Table A-3. Steady State Measurements for PULS QT 20.241

Measurement Parameters	Test Process State 480V 60Hz	Test Process State 380V/50 Hz
Rated Voltage P-P	380-480	380-480
Voltage (V_{a-b})	480	380
Current (I_a)	0.66	0.86
Power (W_{a-n})	171	168
Volt Amps (VA)	183	188
V_{thd} (Phase A) %	1.85	2.42
I_{thd} (Phase A) %	30.62	41.2
I₁	0.63	0.78
I₃	0.02	0
I₅	0.18	0.33
Power Factor	0.93	0.9
Crest Factors	1.54	1.69
Hertz	60	50

Per Section 7.2 of the SEMI F47-0200 and Section 10.3.2 of SEMI F42-0600, tests for a three-phase load without a neutral are to be conducted between each pair of phases, not all three phases simultaneously.

Attachment B - Test Configuration

Test Configuration

The SEMI F42 compliant voltage sag generator was placed in series with the main power feed, in according with SEMI F42 and shown in Figure B-1. The Main power feed for this test was an amplifier that was adjustable for voltage and frequency. This allowed a precise setting of 480Vac 60Hz and 380Vac 50Hz. A photo of the setup is shown in Figure B-2.

Figure B-1 – Test Configuration and Setup

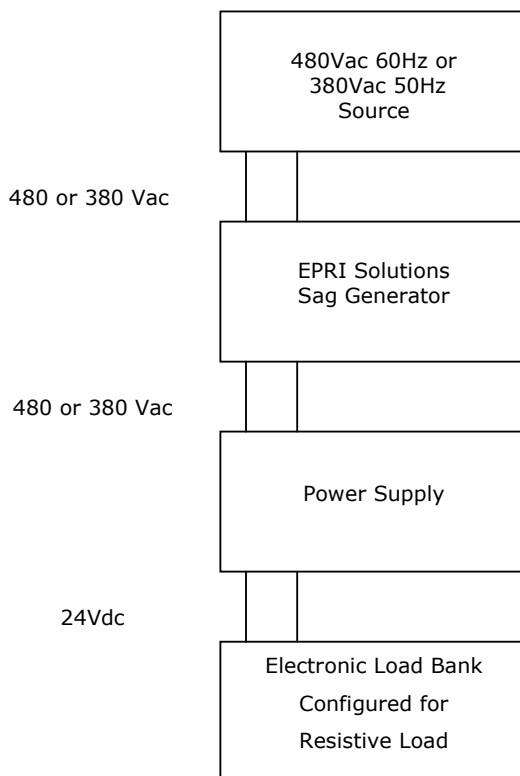
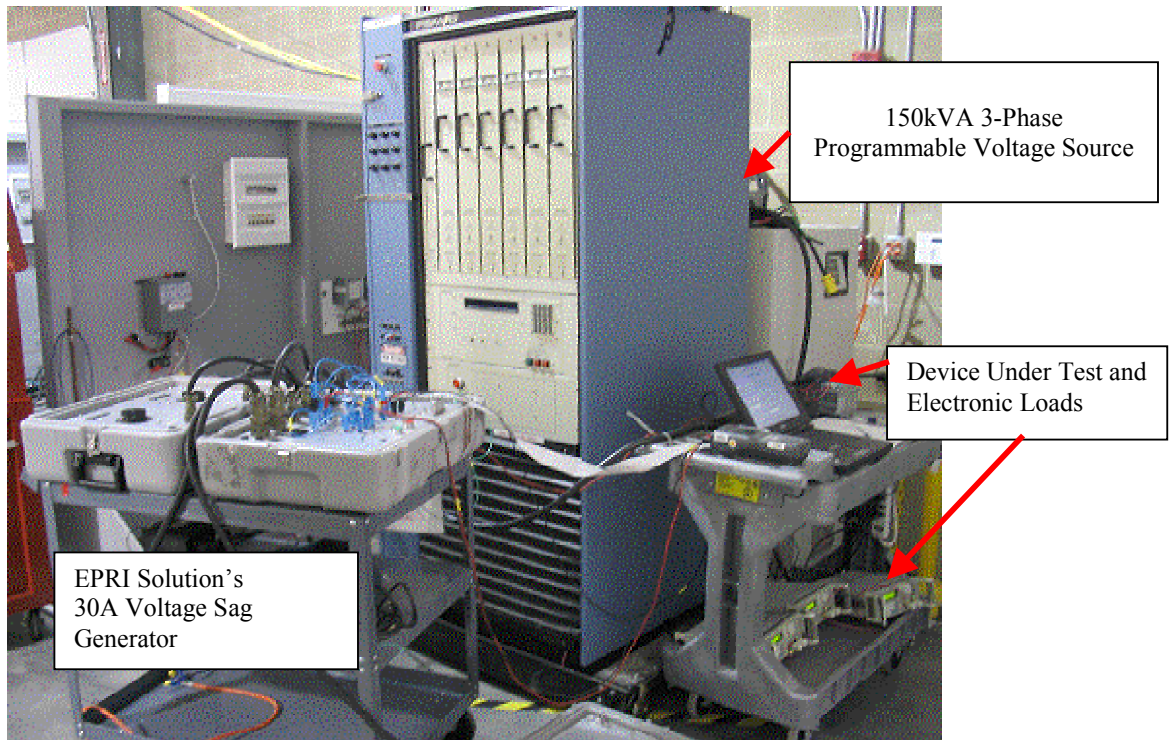

Figure B-2 - Photo of Test Setup



Attachment C - SEMI F47 Abstract

The SEMI F47 “Specification for Semiconductor Processing Equipment Voltage Sag Immunity” document defines the threshold that a semiconductor tool must operate without interruption (per SEMI F42) and it also provides a target for the facility and utility systems. The Recognizing semiconductor factories require high levels of power quality due to the sensitivity of equipment and process controls and that Semiconductor processing equipment is especially vulnerable to voltage sags, this document defines the voltage sag ride-through capability required for semiconductor processing, metrology, and automated test equipment.

The requirements in this international standard were developed to satisfy semiconductor industry needs. While more stringent than existing generic standards, this industry-specific specification is not in conflict with known generic equipment regulations from other regions or generic equipment standards from other organizations. It is the intent of this standard to provide specifications for semiconductor processing equipment that will lead to improved selection criteria for sub-components and improvements in equipment systems design. While it is recognized that in certain extreme cases or for specific functions battery storage devices may be appropriate, it is not the intent of this standard to increase the size or use of battery storage devices provided with equipment. Focus on improvements in equipment component and system design should lead to a reduction or elimination in the use of battery storage devices to achieve equipment reliability during voltage sag events.

The SEMI F47 document specifies the minimum voltage sag ride-through capability design requirements for equipment used in the semiconductor industry. The expected equipment performance capability is shown graphically on a chart representing voltage sag duration and percent deviation of equipment nominal voltage. The primary focus for this specification is semiconductor processing equipment including but not limited to the following tool types:

- Etch equipment (Dry & Wet)
- Film deposition equipment (CVD & PVD)
- Thermal equipment
- Surface prep and clean
- Photolithography equipment (Stepper & Tracks)
- Chemical Mechanical Polishing equipment
- Ion Implant equipment
- Metrology equipment
- Automated test equipment

The actual SEMI F47 ride-through curve is shown below.

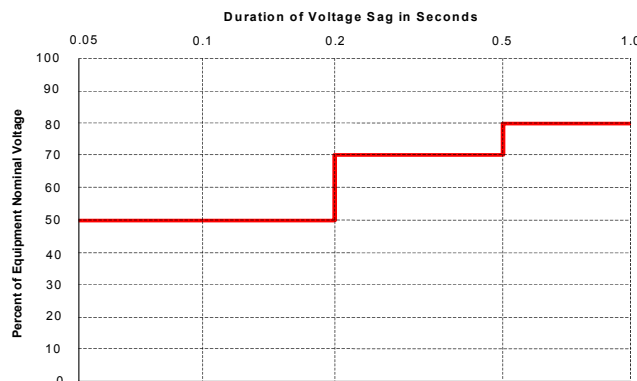

Figure C-1 The SEMI F47 Voltage Sag Ride-Through Curve

The specification states that Semiconductor processing, metrology, and automated test equipment must be designed and built to conform to the voltage sag ride-through capability per the defined curve. Equipment must continue to operate without interrupt (per SEMI E10) during conditions identified in the area above the defined line. In the context of SEMI F47, interrupt means any assist or failure. An assist is defined as an unplanned interruption that occurs during an equipment cycle where all three of the following conditions apply:

- The interrupted equipment cycle is resumed through external intervention (e.g., by an operator or user, either human or host computer).
- There is no replacement of a part, other than specified consumables.
- There is no further variation from specification of equipment operation.

Furthermore, a failure is any unplanned interruption or variance from the specifications of equipment operation other than assists. Although no variation in the tool's process is the goal, this standard addresses these issues as related to the equipment operation only.



942 Corridor Park Boulevard
Knoxville, Tennessee 37932 USA
phone: 865-218-8000
fax: 865-218-8001

www.eprisolutions.com



EPRI Solutions Inc. PQ Star Certification for the Semiconductor Industry

Having conducted power quality tests on hundreds of devices and electrical equipment since 1992, EPRI Solutions is known worldwide for power quality testing expertise. Since April 1997, EPRI Solutions has conducted voltage sag testing on semiconductor processing tools. In order to serve the semiconductor industry, EPRI Solutions Inc. has established a certification program to test manufacturer equipment per established power quality standards. PQ Star certification for the SEMI F47 standard (Specification for semiconductor Processing Equipment Voltage Sag Immunity) is now available for semiconductor equipment suppliers. EPRI Solutions utilizes the SEMI F42 test standard (Test Method for Semiconductor Processing Equipment Voltage Sag Immunity). With the PQ Star certification, EPRI Solutions Inc. offers a third party verification that the equipment tested meets this important new power quality standard.

For more information about the PQ Star test program for the semiconductor industry or inquire about testing, contact Mark Stephens at mstephens@epri-Solutions.com

EPRI Solutions Inc.
942 Corridor Park Blvd
Knoxville, Tennessee 37932
(865) 218-8000
www.f47testing.com